

PLOT AREA = 50.00 Sq.Mt.
LAND USE = INDUSTRIAL

GC, FAR and Setback for all industrial Plots (M0- M5)

Plot Size	Ground Coverage (% of plot size)	FAR	Plot Size	Setback(in mts)			
				Front	Rear	Side-1	Side-2
Upto 100 sqm	60	1.2	Upto 100 sqm	3	-	-	-
101-450 sqm	60	1	101-200 sqm	4.5	1.5	1.5	-
451-2000 sqm	55	0.8	201-300sqm	4.5	2	2	-
2001-12000 sqm	55	0.7	301-400sqm	4.5	3.5	3	-
12001-20000 sqm	50	0.65	401-500sqm	6	3.5	3.5	-
Above 20000 sqm	50	0.6	501-600 sqm	6	4	3.5	3.5
			601-1000	7.5	4.5	4.5	4.5
			1001-5000	9	4.5	4.5	4.5
			5001-30000	9	9	4.5	4.5
			More than 30000	15	9	9	9

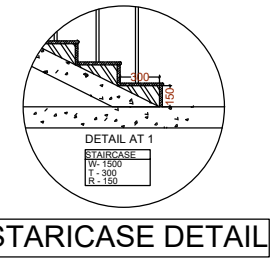
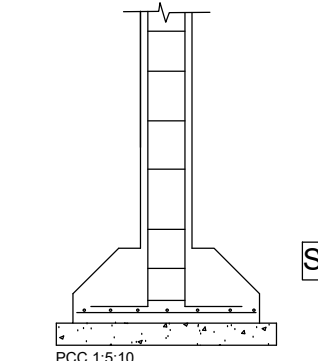
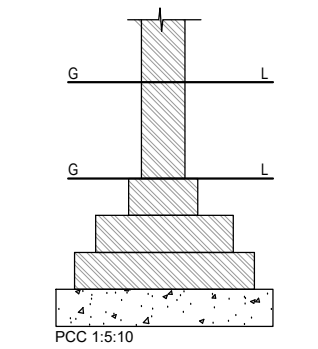
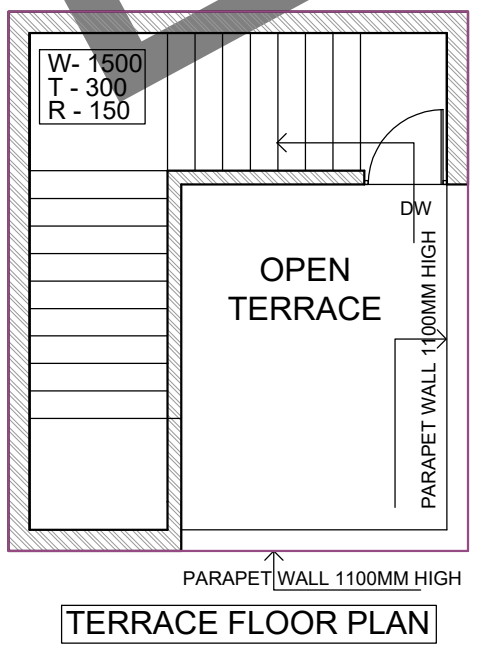
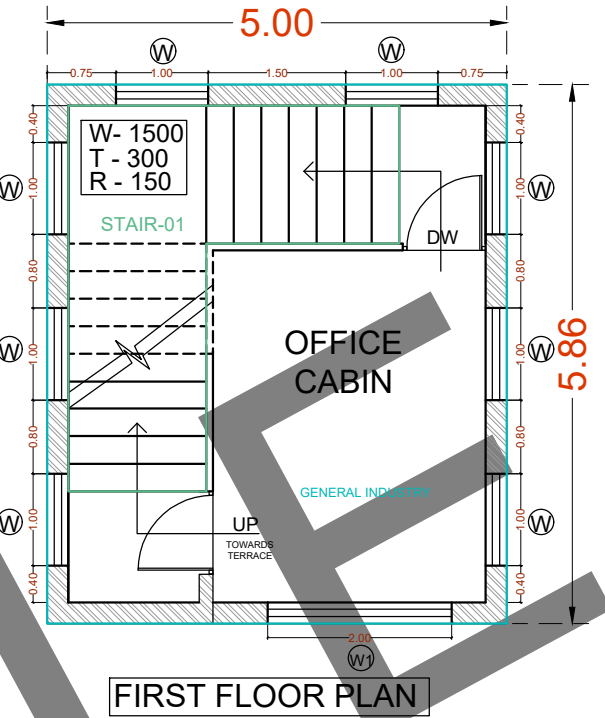
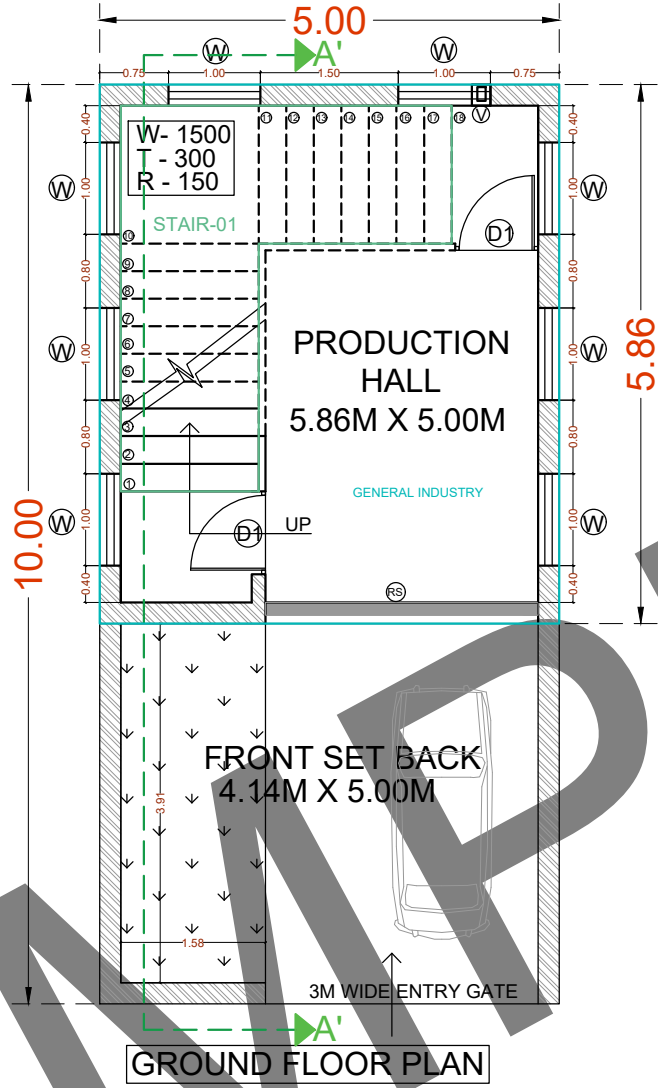
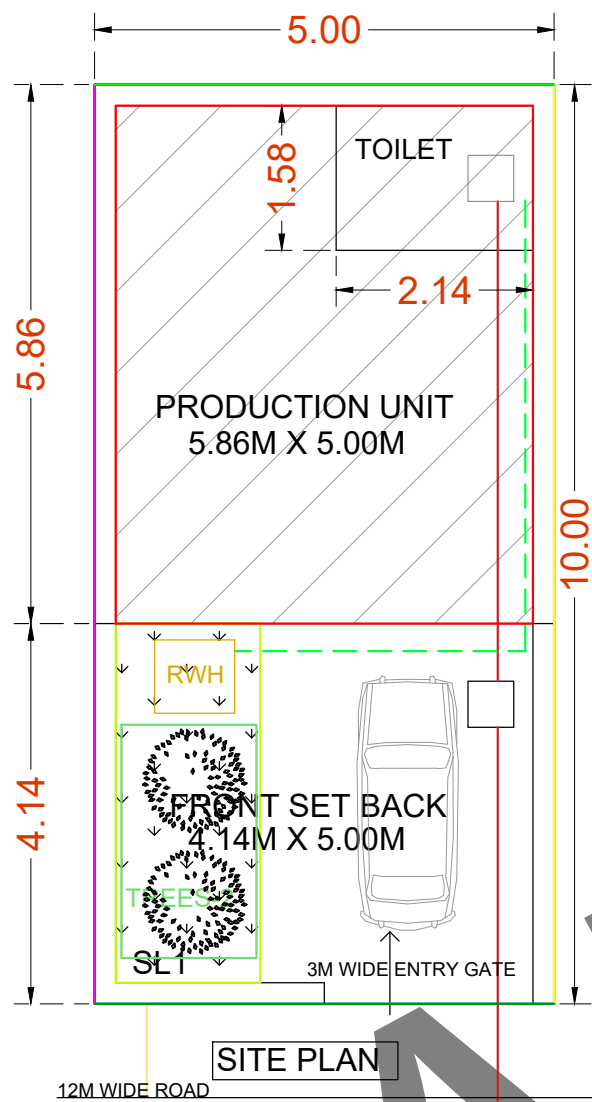

SCHEDULE OF OPENINGS

S.NO.	NAME	TYPE	SIZE
1	D1	DOOR	900 X 2100
2	W	WINDOW	1000 X 1200
3	W1	WINDOW	2000 X 1200
3	V	VENTILATOR	400 X 400
4	RS	ROLLER	3000 X 3500

DOOR WINDOW SCHEDULE

